

DECENTRALIZED CONTROL OF THREE TANK SYSTEM USING LOGICAL SUPERVISOR

Petr Chalupa*, Vladimír Bobál**

*Tomas Bata University in Zlín
Faculty of Technology
Department of Process Control
fax: +420 57603 5279
*email: chalupa@ft.utb.cz
**email: bobal@ft.utb.cz*

Abstract: The paper deals with decentralized control with logical supervisor. The decentralized control is an approach of controlling multi input multi output systems with the same number of inputs as the number of outputs. The logical supervisor was proposed as a possible way of improving the stability and the quality of control courses. The theoretical results are applied to a real-time laboratory control system – DTS200 Three Tank System.

Keywords: decentralized control, logical supervisor, self-tuning control, on-line identification

1. INTRODUCTION

The classical approach to the control of MIMO systems is based on the design of a matrix controller to control all system outputs at one time. Computation of the matrix controller is realized by one central computer. The basic advantage of this approach is the possibility of achieving optimal control performance because the controller can use all information known about the controlled system. The disadvantage of using a central matrix controller is its demand on computer resources because the number of operations and required memory depend on the square of the number of controlled signals.

Nowadays this problem is reduced thanks to great progress in the development of computer hardware; this, however, increases the price of the control system. Another disadvantage is the influence central controller faults on the controlled system. If the central controller fails, all the controlled signals are affected; thus the reliability of the controller is fundamental. Ensuring the required reliability can be unbearable from the financial point of view, especially in critical applications.

2. DECENTRALIZED CONTROL

An alternative solution to the control of MIMO systems is a decentralized approach. In this case, the system is considered as a set of interconnected subsystems and the output of each subsystem is influenced not only by the input to this subsystem but also by the input to the other subsystems (Aoki, 1972). Each subsystem is controlled by a stand-alone controller. The simplest case of control circuit of two input two output (TITO) system is shown in Fig. 1.

Thus, decentralized control is based on decomposition of the MIMO system to subsystems, and the design of a controller for each subsystem (Cui and Jacobsen, 2002). Another advantage of the decentralized approach is that it is a lot easier to set controller parameters (e.g. choice of poles of the characteristic polynomial) for SISO control loops than for MIMO control loops. On the other hand, the control performance of a decentralized control system is suboptimal because controllers do not use information from the other subsystems. A further disadvantage is the limited applicability of the

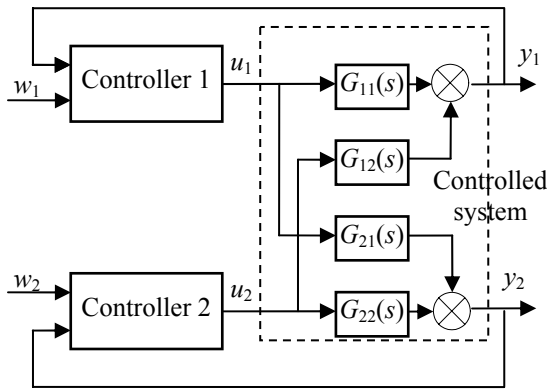

Fig. 1. Decentralized control of TITO system

decentralized control to symmetric systems (systems with an equal number of inputs and outputs).

Each output of a multivariable controlled system can be affected by each system input. The strength of the effect is determined not only by internal transfers of the MIMO system but also by the evolution of the system input signals. When the decentralized approach is used to control such a system then, from the point of view of a controller of a particular subsystem, the transfer function varies in time even if the MIMO system is linear and stable.

The presence of subsystem interconnections is the main reason for using self-tuning controllers (Bobál *et al.*, 2005) in a decentralized approach to ensure the required course of controlled variables. Identification algorithms suitable for use in decentralized control must include weighting of identification data such that new data affect model parameters estimation more than older data. This requirement is a consequence of the time-varying influences of other subsystems on the identified subsystem. The influence of control variable (u_i) on the corresponding controlled variable (y_i) decreases with increasing gain of subsystem interconnections. This could lead to an unstable process of recursive parameter estimates.

3. SUPERVISORY SYSTEM

The stability of recursive identification can be increased by ensuring that just one of the controllers connected to the multivariable systems works in an adaptive regime at a particular time. Recursive identification parts of other controllers are suspended and parameter model estimates are constant for that time.

The process of switching on and off recursive identification is controlled by a new part of the control circuit – the supervisory system. Switching the identification on and off can be described as a process of transferring tokens among subsystems where only the controller, which currently has a

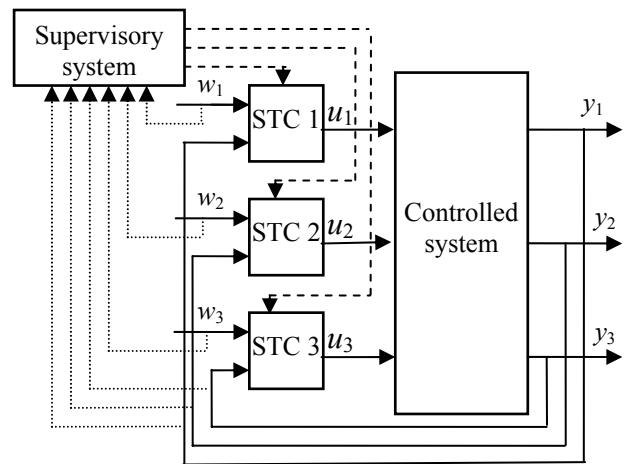

Fig. 2. Decentralized control circuit with supervisory system

token, can perform recursive identification. The token is moved to an other subsystem when a selected criterion is used.

The supervisory system represents a second level of control and thus a control circuit with supervisory system has a hierarchical control structure. An example of a control circuit scheme with supervisory system is shown in Fig. 2. The first (lowest) level of hierarchy contains individual self-tuning controllers (STC 1, STC 2 and STC 3 in Fig. 2) and the second level (superior) is represented by a supervisory system, which controls individual self-tuning controllers. The supervisory system analyses particular values from the control circuit and on the basis of these analyses moves the identification token among subsystems. In the case shown in Fig. 2, the analysis is performed on the basis of reference values and controlled values (dotted lines) and the process of transferring token is represented by dashed lines.

4. LOGICAL SUPERVISOR

A logical supervisor has been proposed to utilize and simplify the design of a supervisory system. This approach is suitable for use in real-time industrial applications. The idea of a logical supervisor is based on the following two principles:

- assigning priorities to individual subsystems;
- on-line evaluation of criteria for each subsystem.

The situation that reaching the reference value is more important for some subsystems than for others is very common, especially in industrial applications. It is thus possible to assign a unique priority to each subsystem. The priority corresponds to the importance of the subsystem's output. The numbering of subsystems is just a formal problem and thus the subsystems can be numbered according to priorities. The first subsystem has the highest

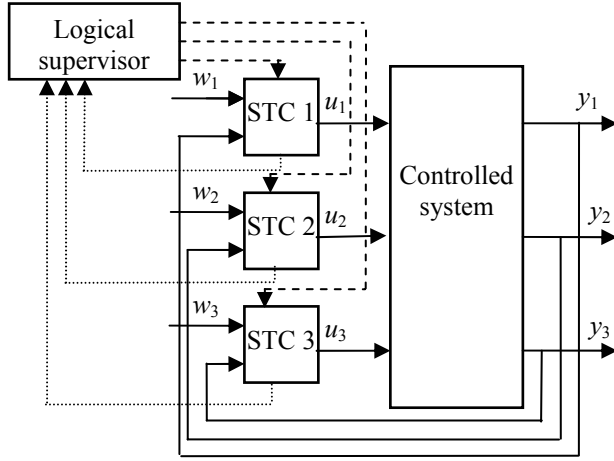

Key:

- Real signals
 - Adaptation required
 - Adaptation enabled
- } boolean signals

Fig. 3. Decentralized control circuit with logical supervisor

priority; the second subsystem has the second highest priority and so on.

Further, for each subsystem, a criterion which determines whether the subsystem requires switching to adaptive mode or not, is calculated. The criterion can be designed with respect to particular properties of the subsystem. The block responsible for computing the criterion can be encapsulated with the self-tuning controllers and the output, which is sent to the logical supervisor, is a Boolean value determining whether or not the subsystem requires adaptation.

The last part of the logical supervisor approach is a superior logic determining which of subsystems requiring adaptation will be switched to adaptive mode. The decision-making is based on priorities assigned to individual subsystems. If the first subsystem requires switching to adaptive mode it is always satisfied; if the second subsystem requires switching to adaptive mode, it is satisfied only if the first subsystem does not require switching to adaptive mode, etc. The control circuit schema with logical supervisor approach and a controlled system of three inputs and three outputs is shown in Figure 3 when only one of the dashed signals, “Adaptation enabled”, is switched on at a time.

The logical supervisor uses only the logical values on its input and provides logical values on its output. In addition, the relations between inputs and outputs are simple logical functions. The transfer function between the input and output signals of the logical supervisor can be arranged as a table of logical values. This situation is shown in Table 1 for the MIMO system of three inputs and three outputs.

Table 1 Relation between inputs and outputs of logical supervisor

Adaptation required (inputs)			Adaptation enabled (outputs)		
Subsy stem 1	Subsy stem 2	Subsy stem 3	Subsy stem 1	Subsy stem 2	Subsy stem 3
R_1	R_2	R_3	E_1	E_2	E_3
0	0	0	0	0	0
0	0	1	0	0	1
0	1	0	0	1	0
0	1	1	0	1	0
1	0	0	1	0	0
1	0	1	1	0	0
1	1	0	1	0	0
1	1	1	1	0	0

It is also possible to rewrite the relation between inputs (R_k) and outputs (E_k) using logical operators:

$$\begin{aligned}
 E_1 &= R_1 \\
 E_2 &= \overline{R_1} \text{ AND } R_2 \\
 E_3 &= \overline{R_1} \text{ AND } \overline{R_2} \text{ AND } R_3
 \end{aligned} \tag{1}$$

where the bar denotes negation of a variable and function AND represents logic product.

When determining signal “Adaptation enabled” for general controlled MIMO system, the following relation is valid:

$$E_k = \prod_{i=1}^{k-1} \overline{R_i} \text{ AND } R_k \tag{2}$$

where Π stands for logic product.

The logical supervisor represents a reliable approach to design of supervisory logic for decentralized control. The advantage of this approach is its simplicity of implementation and small number of signals that are transferred from subsystems to supervisory system and back.

5. THREE TANK SYSTEM

The logical supervisor approach was verified by the control of laboratory model DTS200 “Three-Tank-System” by Amira.

The system consists of three interconnected cylindrical tanks, two pumps, six valves, pipes, measurement of liquid levels and other elements. The schema of the system is shown in Fig. 4. The pump P1 controls the inflow to tank T1 while the pump P2 controls the liquid inflow to tank T2. There is no pump connected to tank T3. The characteristic of the flow between tank T1 and tank T3 can be affected by valve V1, flow between tanks T3 and T2

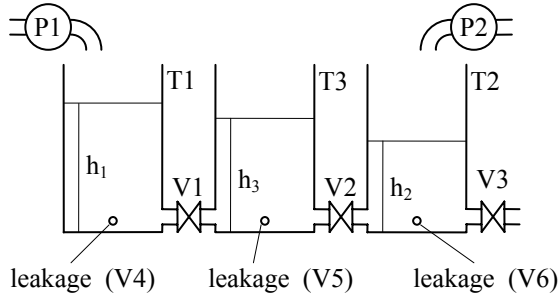

Fig. 4. Schema of three-tank system

can be affected by the valve V2 and the outflow of the tank T2 is can be affected by valve V3. The system also provides the capability of simulating leakage from individual tanks by opening the valves V4, V5 and V6.

The valve states didn't change during the experiments and were positioned as follows: valves V1 and V2 were fully opened, valves V5 and V6 were fully closed and valves V3 (outflow) and V4 (leakage of tank T1) were approximately in the midpoint of their control range.

The controlled values during the experiments were liquid levels of tanks T1 and T2. The control signals were voltages of the motors of the pumps P1 and P2. Decomposition of this TITO system into subsystems for application of decentralized control is straightforward in this case. The pump P1 is used to control level in the tank T1 and the pump P2 controls the level in the tank T2.

Corresponding Simulink control circuit with the logical supervisor is shown in Fig 5. Pole placement self-tuning controllers *pp2b_1* from the Self-tuning Controllers Simulink Library (Bobal and Chalupa 2002) were used. The self-tuning controllers use second order models of controlled processes. The transfer function of the model is stated by the equation 3.

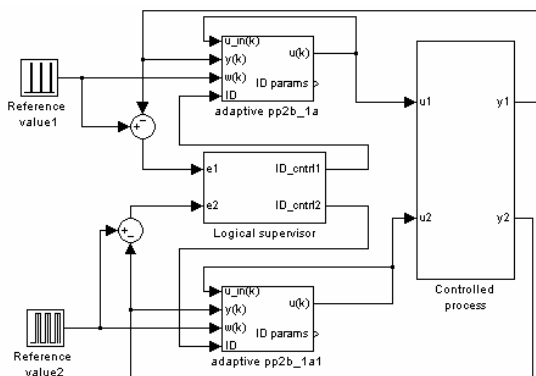

Fig 5. Simulink schema of control circuit

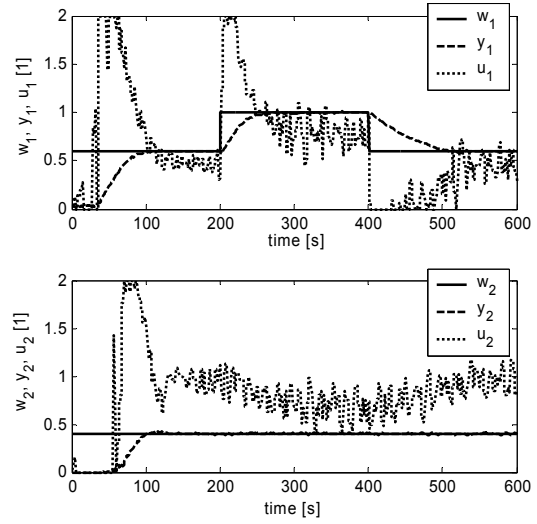

Fig. 6. Control courses without logical supervisor

$$G(z^{-1}) = \frac{b_1 z^{-1} + b_2 z^{-2}}{1 + a_1 z^{-1} + a_2 z^{-2}} \quad (3)$$

The initial parameter estimations was set without using any apriori information of the system. Initial estimations according to equation 4 were used in both controllers in all experiments.

$$[a_1, a_2, b_1, b_2] = [0.1, 0.2, 0.3, 0.4] \quad (4)$$

The least squares method with adaptive directional forgetting (Kulhavy, 1987) was used for on-line calculation model parameters.

The sample time of $T_0=2$ was used. The request of on-line identification was calculated on base of course of control error in this case.

5.1 Control courses without logical supervisor

The control without the logical supervisor was performed first to obtain base data for comparison of the effect of the incorporation of logical supervisor into control circuit.

The courses of reference value, control value and controlled value are shown in Fig. 6. The first subsystem consists of the pump P1 as an input and height of liquid level in tank T1 (h_1) as an output. The second subsystem consists of the pump P2 as an input and height of liquid level in tank T2 (h_2) as an output. The tank T2 serves as a reservoir of liquid to make easier the control of liquid level in tank T1. The control signals are limited to the range from 0 to 2. Where the value of zero corresponds to zero inflow and the value of 2 corresponds to maximal inflow

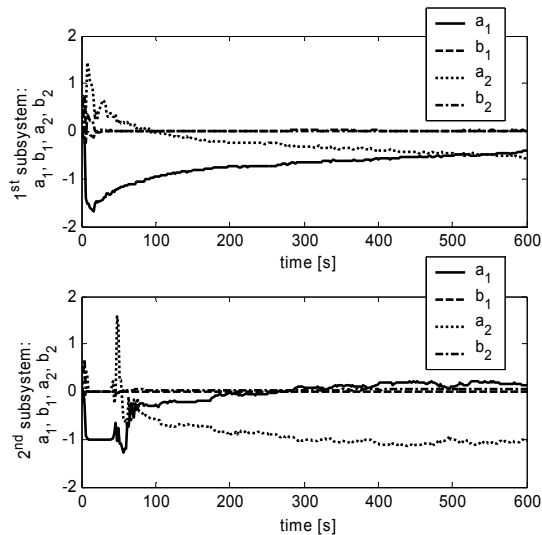

Fig. 7. Course of identification parameters during the control process without using logical supervisor

The courses of estimations of parameters of these models are shown in Fig. 7.

5.2 Control courses with logical supervisor

The same course of reference signal was used also for the control with logical supervisor incorporated into control circuit. The first subsystem consists of the pump P1 as an input and height of liquid level in tank T1 (h_1) as an output. This subsystem has higher priority when requesting identification. The second subsystem consists of the pump P2 as an input and height of liquid level in tank T2 (h_2) as an output. The tank T2 serves as a reservoir of liquid to make easier the control of liquid level in tank T1. The priority of identification request of this subsystem is lower than the priority of the first subsystem.

The courses of reference signal, controlled signal and control signal are shown in Fig. 8. The courses of identification parameters is shown in Fig. 9.

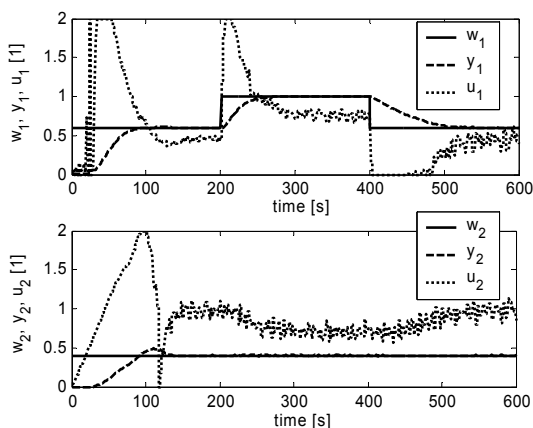

Fig. 8. Control courses without logical supervisor

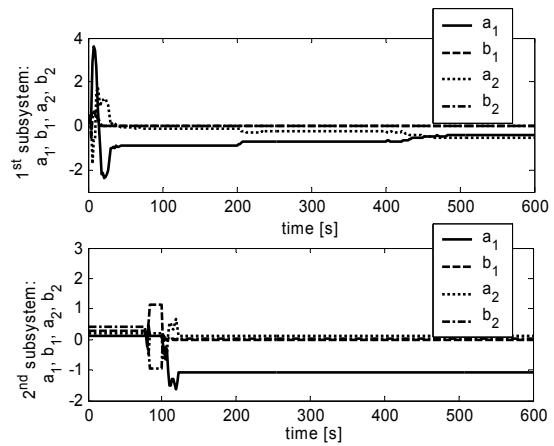

Fig. 9. Course of identification parameters during the control process with using logical supervisor

The values of identification request and identification enabled signals was also recorded for this control process. The results are presented in Fig. 10. Simple method of generating identification requests was used. The boolean value of identification request signal is determined just by the absolute value the current control error. It can be seen that both subsystems requested identification in the beginning of control process. But just the request of the first subsystem was satisfied.

5.3 Comparison of control results with and without logical supervisor

Figures 6 and 8 contain control courses of the systems without and with logical supervisor respectively. It can be seen from the Fig. 6 that the on-line identification of the second subsystem was not accurate in the first approximately 50 seconds. The control process remained stable just because the saturation of the control signal while the controller itself produced negative outputs. The small overshoot of the second subsystem in the Fig. 8 is caused by insufficient time for the identification of this subsystem and very simple method of generating

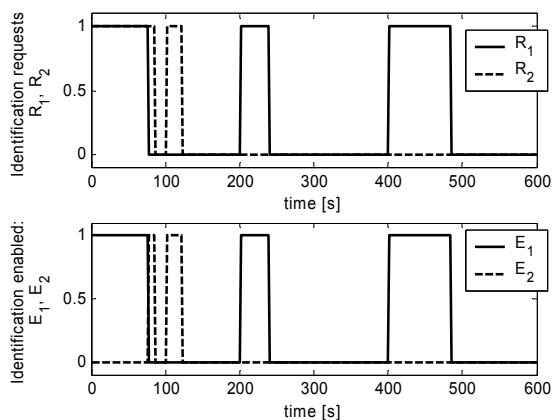

Fig. 10. Course of identification requests and identification enabled signals

identification request signals. Described method of generating identification requests led to the situation in time of about 100s where the absolute value of the control error of the second subsystem was close to zero and thus identification was not requested although on-line identification of this subsystem had not been finished yet.

By comparing courses of model parameter estimations in Fig. 7 and 9 can be seen that the system with logical supervisor does not suffer from the drift of parameters. This drift can be observed especially in the course of parameters a_1 and a_2 of the first subsystem In Fig. 7.

The control courses were also compared by calculating the two quadratic criterions of quality of controlled process. The first criterion used evaluates control error and is determined by equation 5.

$$S_e = \sum_{k=0}^N [w(k) - y(k)]^2; \quad N = 300 \quad (5)$$

The second criterion used is based on differences of control signal and is determined by equation 6.

$$S_u = \sum_{k=1}^N [u(k) - u(k-1)]^2; \quad N = 300 \quad (6)$$

The results for both control circuit and both subsystem are arranged in table 2.

Table 2 Comparison by quadratic criterions

		subsystem		total
		1 st	2 nd	
without	S_y	11.64	5.84	17.48
logical supervisor	S_u	14.76	10.08	24.84
with	S_y	11.04	4.55	16.59
logical supervisor	S_u	13.39	4.87	18.26

It can be calculated that the system with logical supervisor produced better results. The difference was in range of tens of percent.

6. CONCLUSION

Logical supervisor as a hierarchical element in the decentralized control circuit was presented in this paper. The logical supervisor is responsible for enabling just one self-tuning controller to be in the adaptation phase at a particular time. Real-time experiments demonstrated that usage of logical supervisor can improve stability and accuracy of controlled process.

7 ACKNOWLEDGMENT

This work was supported by the Ministry of Education of the Czech Republic under grant 1M6840770004.

REFERENCES

- Aoki, M. (1972). On feedback stabilizability of decentralized dynamic systems, *Automatica*, **8**, Issue 2, pp. 163-173.
- Bobál, V., J. Böhm, J. Fessler and J. Macháček (2005). *Digital Self-tuning Controllers: Algorithms, Implementation and Applications*, Springer, Berlin.
- Bobál, V. and P. Chalupa (2002): *Self-Tuning Controllers Simulink Library*, <http://www.utb.cz/stctool/>
- Cui H. and E. W. Jacobsen (2002). Performance limitations in decentralized control, *Journal of Process Control*, **12**, pp. 485-494.
- Kulhavy, R. (1987). Restricted exponential forgetting in real time identification, *Automatica* **23**, pp. 586 - 600.